

Assembly Instruction for C6-Series Module with PressFIT PIN

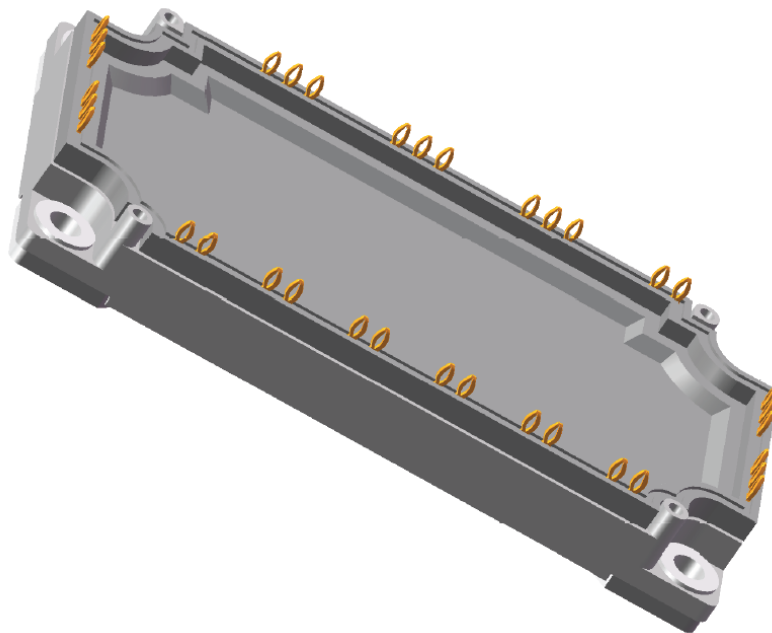

Content

1	General Information	3
1.1	Introduction	3
1.2	Module Dimensions	3
2	Requirements for PCB	4
3	Fixing PCB on Heat Sink	4
4	Press-in Process	5
4.1	Introduction of Press-in Process	5
4.2	TIM-Module	5
5	Requirements for Heat Sink	6
6	Applying of Thermal Conductive Paste by Screen Printing	6
7	Assembling C6-Module on Heat Sink	7
8	Fixing PCB with Self-tapping Screws	8

1 General Information

1.1 Introduction

STARPOWER C6 Power Modules provide ultra low conduction loss as well as short circuit ruggedness. They are designed for the applications such as general inverters and UPS.

1.2 Module Dimensions

[Figure 1] shows the technical drawing of C6-module. The main dimensions and screw specifications are listed in [Table 1].

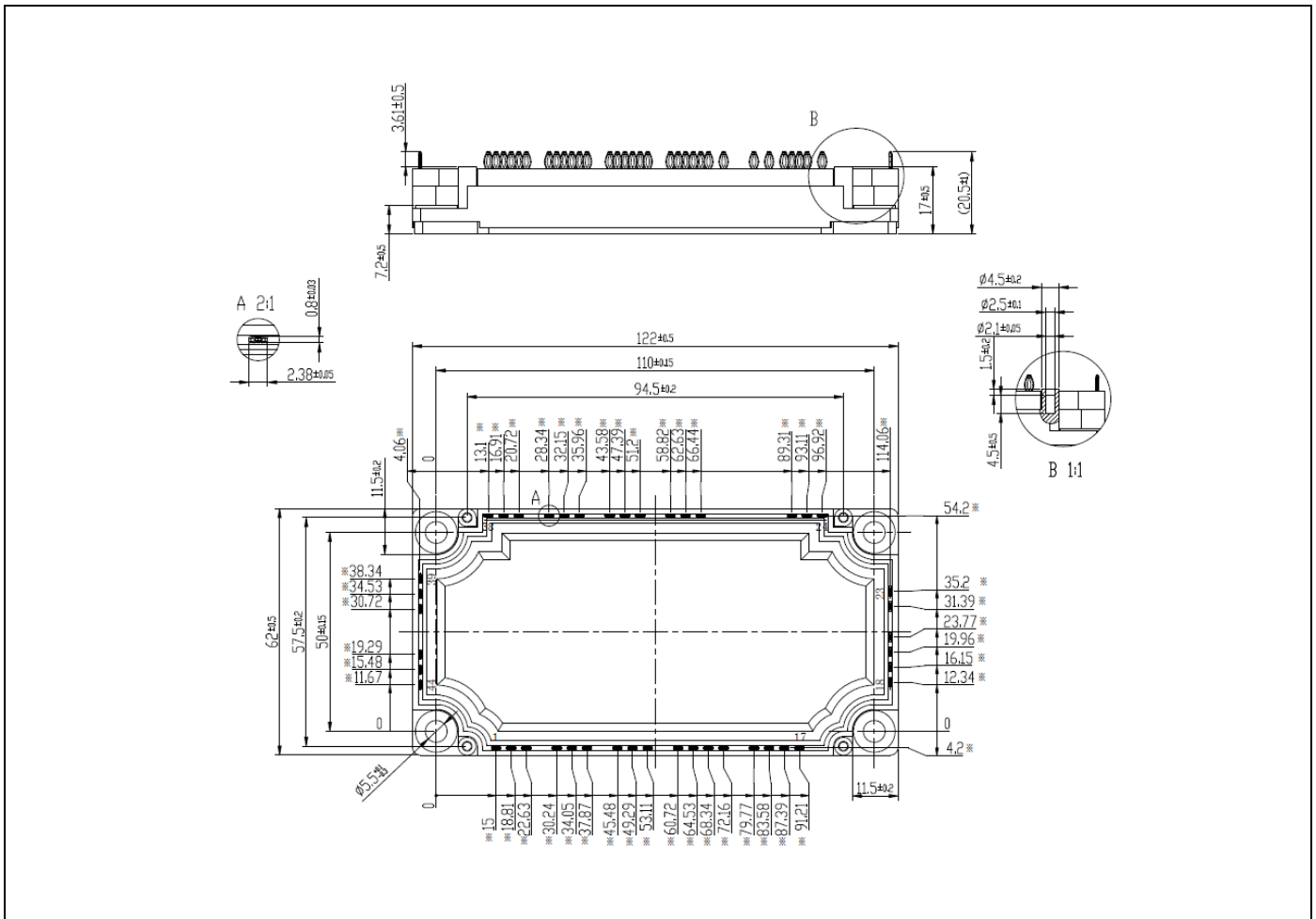

Figure 1: Technical drawing of C6-module.

Table 1: Main dimensions and screw specifications.

Item	Specification
Length	122 mm
Width	62 mm
Height	20.5 mm
Base plate mounting screw	M5

2 Requirements for PCB

The PressFIT technology used in the C6-series modules has been inspected and qualified by Starpower AG in China for Standard FR4 PCB's with tin applied chemically (IEC 60352-5).

Correct design of the plated through holes (PTH) in the PCB is essential to obtain a reliable connection between PTH and PressFIT PIN. [Table 2] lists the requirements of the PCB.

Table 2: Requirements for PCB.

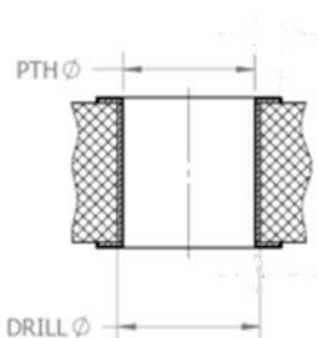
	Metric	
Drill diameter	$\Phi 2.35 \pm 0.05$ mm	
Copper thickness	≥ 25 μ m	
Diameter of Plated-through hole (PTH)	$\Phi 2.14 \sim 2.29$ mm	

3 Fixing PCB on Heat Sink

The PCB has to be fixed on the heat sink by a support pillar to minimize the mechanical stress on the Pressfit PIN, as shown in [Figure 2]. The number and position of the support pillar are designed according to the system. The height between heat sink and PCB are determined by the press-in process and the tool. In order to reduce the PCB deformation, the recommended height of the support pillar is between 17.3 mm and 17.6 mm.

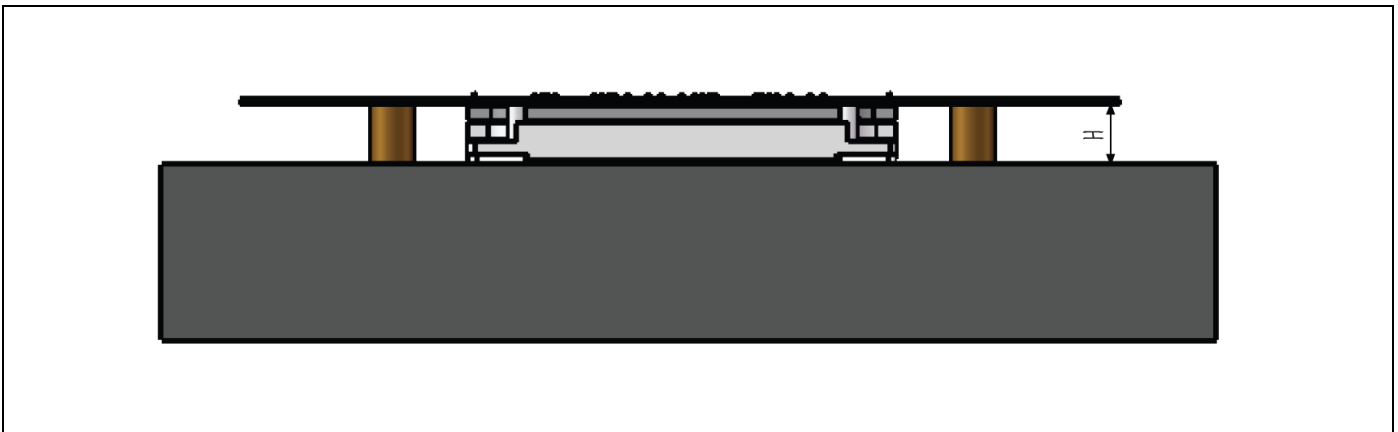

Figure 2: Mounting a PCB to the heat sink.

4 Press-in Process

4.1 Introduction of Press-in Process

This section introduces the necessary press-in force and tools for the press-in process. The PressFIT module is pressed into a PCB by using a toggle lever press. A suitable PressFIT speed is chosen to avoid deformation of the pins or a non-gas-tight connection. [Figure 3] shows the assembly drawing of press-in tool. The parameters for press-in process are listed in [Table 3].

The general press-in process can be divided into four steps.

1. The press-in tool and supporting tool should be aligned in the vertical direction to protect the bottom of the module from damage.
2. PCB is placed on the supporting tool and fixed by positioning pins.
3. The module is placed on top of the PCB and fixed by the positioning pins.
4. The upper press-in tool moves downwards to press the module into PCB.

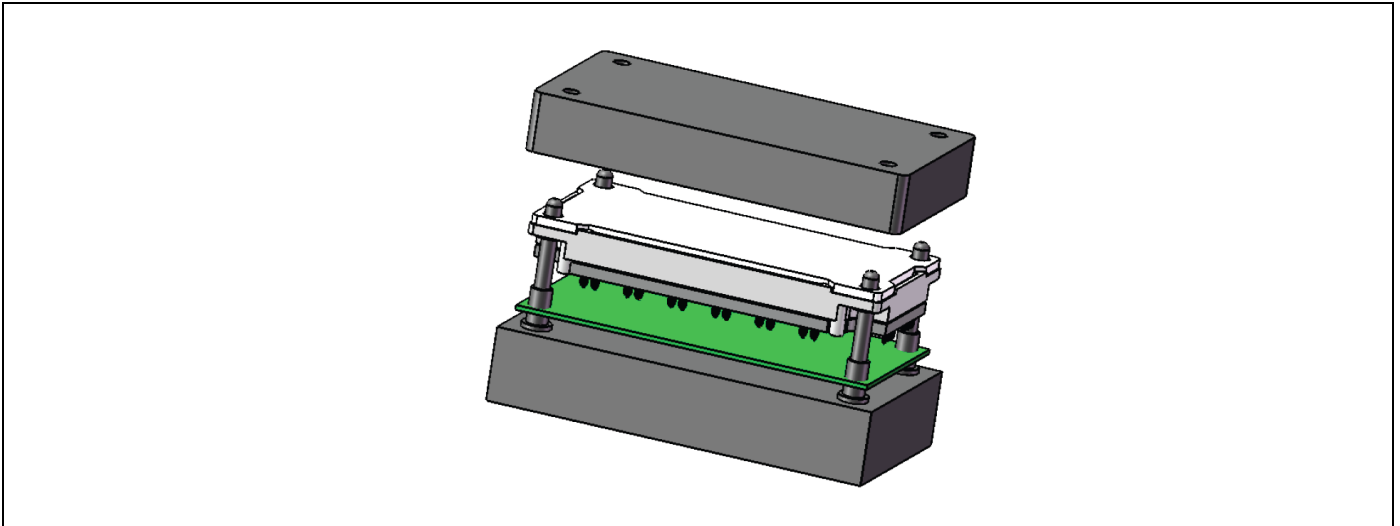

Figure 3: Schematic of press-in process.

Table 3: Parameter for press-in process.

Description	Unit	Min.	Typ.	Max.
Press-in speed	mm/min	25	100	-
Max allowed press force per pin	N	-	70	-

4.2 TIM-Module

TIM, a material optimized for semiconductor power modules providing long-term stability and thoroughly excellent properties. Please refer to [Figure 3], it shows the areas of the C6S base plates where TIM is applied.

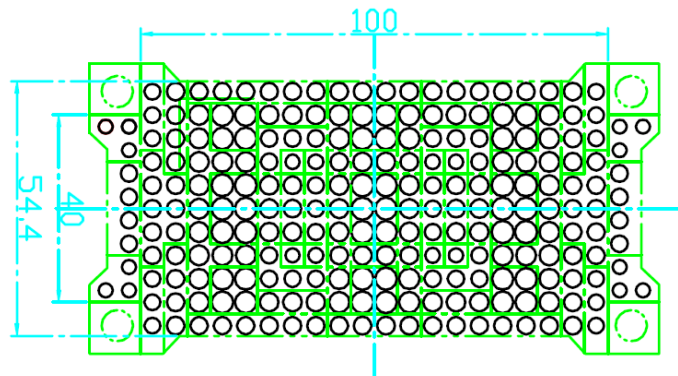

Figure 4: The areas of the C6S base plates where TIM is applied.

5 Requirements for Heat Sink

The contact surface between the base plate and the heat sink must be kept clean, free of any contamination to avoid excessive mechanical stress and increased thermal resistance to the module. The heat sink must have sufficient rigidity to meet assembly and shipping requirements without introducing additional stress or strain on the base plate.

The surface of the heat sink should meet the following requirements:

- surface flatness $< 50 \mu\text{m}$ (related to a length of 100 mm).
- surface roughness $R_z < 10 \mu\text{m}$.

6 Applying of Thermal Conductive Paste by Screen Printing

The thermal conductive paste with permanently elastic properties and a favorable heat transfer resistance is selected to fill the gap between two contact surfaces. Screen print process is recommended to apply the thermal conductive paste for a homogenous and reproducible layer thickness. Before the module is mounted on the heat sink, it is recommended to apply the thermal conductive paste with a thickness between 120 and 150 μm to the underside of the module or to the heatsink.

7 Assembling C6-Module on Heat Sink

C6-module is mounted on the heat sink using M5 screws and flat washers. [Table 4] describes the recommended parameters to mount C6-module on heat sink.

In addition, some requirements must be considered when installing the module on the heat sink.

1. It is recommended to mount the module on the heat sink in the following sequence: 1→3→4→2, as shown in the [Figure 5].
2. First tighten the screws slightly with a torque between 0.5 Nm and 1 Nm. Then tighten the screw firmly to the heat sink with a torque in the range of 3 Nm to 6 Nm.
3. The length of the screw is chosen according to the thread length into the heat sink. The recommended thread length into the heat sink should be min. 5 mm.
4. Screw with non-slip washer is required if the module is used under vibration situation.

Table 4: Recommended parameters for heat sink mounting.

Description	Specification
Mounting screw	M5 x 10mm (The effective thread length into the heat sink is not less than 4 mm)
Recommended washer	M5
Pre-tightening torque	0.5 - 1 Nm
Tightening torque	3 - 6 Nm
Screw velocity (pre-tightening)	Max. 800 rpm
Screw velocity (tightening)	Max. 15 rpm
Thread length into the heat sink	Min. 4 mm

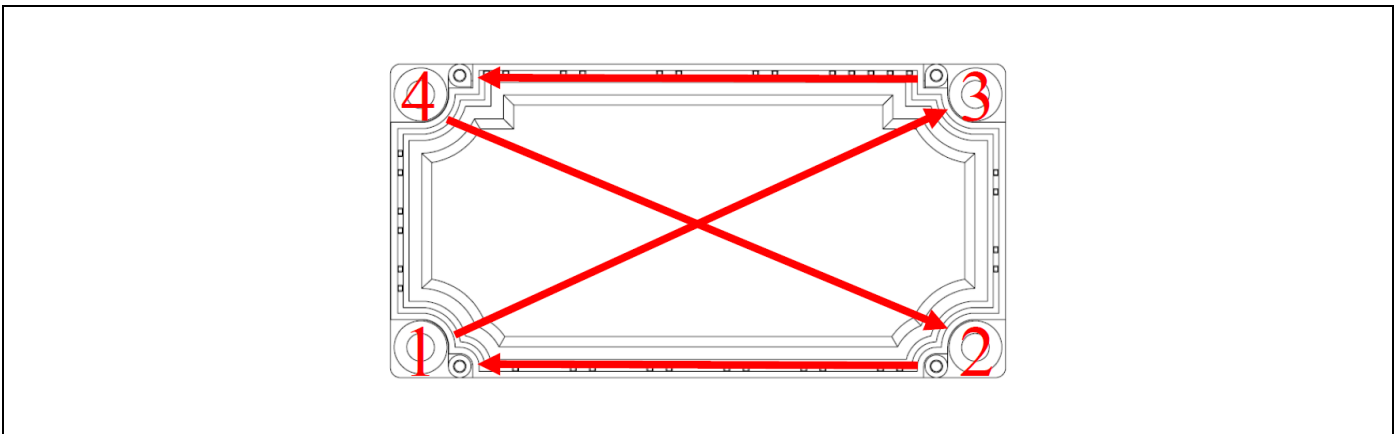

Figure 5: Fastening sequence on the heat sink.

8 Fixing PCB with Self-tapping Screws

At the top of the module there are mounting holes for self-tapping screws for fixing PCB. Customers can decide whether to use this mounting holes according to their actual conditions.

The recommended self-tapping screw is M2.5 with an effective thread length between 4 mm and 10 mm. The effective thread length varied with PCB thickness, see [Table 5].

Table 5: Effective thread length based on PCB thickness.

PCB thickness	0.5 mm	1.0 mm	1.5 mm	2.0 mm	3.0 mm
Effective thread length	5 mm	6.0 mm	6.0 mm	7.0 mm	8.0 mm

Before installing the self-tapping screws, make sure the PCB holes are aligned with the mounting holes of self-tapping screws. The self-tapping screws should be inserted vertically throughout the process, as shown in [Figure 6].

The depth of the top 1.5 mm of the mounting hole for self-tapping screws is the unthreaded insertion area, no torque needs to be applied in this distance. After that, the installation torque on the self-tapping screw should not exceed 0.5 Nm.

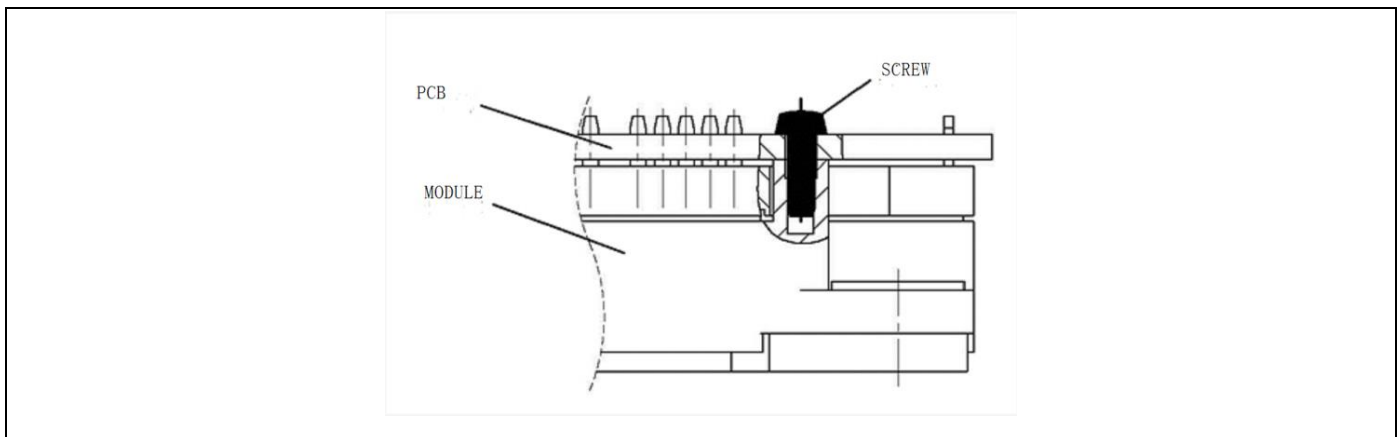

Figure 6: Align PCB to the power module.